

E **ELEKTRA SelfTec[®]** **Antifrost System**

ELEKTRA selfregulating heating cables:

- Are certified by BBJ SEP according to EU standards;
- Are manufactured according to the ISO 9001 Quality Assurance System.



A **Application**

Antifrost protection of:

- Pipes and pipelines;
- Gutters and down pipes;
- Valves and water taps;
- Hydraulic cylinders;
- Locks, bolts, and other mechanical elements.

Antifrost system features

Even in the most adverse winter weather conditions, the ELEKTRA SelfTec[®] system protects gutters, down pipes, valves and other objects liable to get damaged due to low temperatures. Once you have the ELEKTRA SelfTec[®] Antifrost System installed, you do not have to be anxious of cracked pipelines, icicles hanging from the gutters, blocked down pipes etc.

With the ELEKTRA SelfTec[®] Antifrost System installed you need not be worrying any more whether your water supply lines or water valves, both in the non-heated parts of your house, and outside, get frozen.

The ELEKTRA SelfTec[®] system operation is based on the phenomenon of selfregulation of heating cables.

SELFREGULATION

The selfregulation feature of heating cables consists in their capability to produce varying amount of heat (power) depending on the environment conditions (temperature). When the system is switched on while the protected object is still cold, the heating cable warms up working at higher power, and the other way round: as the protected object attains higher temperature, the heating cable operates at lower power, and produces less heat. The increase of the amount of heat emitted by a heating cable is caused by concentration of molecular conductors in the structure of the heating cable, and consequently by reduced electrical resistance and increased current intensity. On the other hand, the reduction of thermal productivity to minimum is caused by significant expansion of molecules causing almost total break of electrical connections, and rise of resistance.

ELEKTRA SelfTec[®] Antifrost System is suitable for operation at typical single phase voltage of 230V~.

ELEKTRA SelfTec[®] Antifrost System keeps patency and flowability of pipeworks, protects buildings and people regardless from the amount of precipitation and value temperature drops. Install ELEKTRA SelfTec[®] Antifrost System now, and forget the trouble of frozen pipelines and gutters when a frosty winter comes. You just have to remember to switch off the system if the ambient temperature rises above zero.

A Antifrost system advantages

EASY INSTALLATION

ELEKTRA SelfTec[®] Antifrost System cables are designed to be laid directly on the protected object like e. g. a pipe segment, a valve, a gutter. ELEKTRA SelfTec[®] Antifrost System cables can also be used with objects made from plastic. Unlike some other heating cables, the selfregulating ELEKTRA SelfTec[®] Antifrost System cables even at low temperatures remain flexible and are easily installable.

RELIABLE DESIGN

The core is made of cross-linked polymer with the addition of carbon, extruded in-between parallel supply wires, powered from one end. Thanks to this design, in case of a local overheating, only the overheated part of the cable does not operate, while the remaining cable length maintains its properties.

Braided copper tin-plated protective screen virtually does not cause any worsening of cable flexibility.

Outer coat of modified polyolefins significantly improves cable mechanical features.

OPERATIONAL COMFORT

ELEKTRA SelfTec[®] Antifrost System works always when desired - no need to worry about unexpected changes of weather or temperature. The system automatically adjusts the cable temperature to the ambient temperature as follows- if ambient temperature falls the power of the heating cable rises.

SAFETY

Selfregulating heating cable is screened on its whole length, and the screen is neutralised or earthed. Simple and fast connection of the system to power supply is accomplished by the means of specially provided 3-meter connection cable permanently fitted with a power plug.

Thanks to selfregulation feature of ELEKTRA SelfTec[®] heating cables, proper temperature is maintained along the whole length of the circuit, while the risk of overheating and burning cables at crossing points is eliminated.

LOW OPERATING COSTS

All heating cables are selected for the worst weather conditions. In order to reduce the operating costs of the ELEKTRA SelfTec[®] heating system is required to turn it off at temperatures above 0°C.

T Types of antifrost system kits

Even at worst winter weather ELEKTRA SelfTec® Antifrost System protects water pipelines, hydraulic cylinders and other objects damageable due to the effect of low temperatures.

Having reliable, easily installable ELEKTRA SelfTec® Antifrost System you can forget frozen and broken pipes in winter time.

CABLE TYPE	HEATING CABLE LENGTH [m]	HEAT OUTPUT [W] (+10°C)
SelfTec® 16/1	1	16
SelfTec® 16/2	2	32
SelfTec® 16/3	3	48
SelfTec® 16/5	5	80
SelfTec® 16/7	7	112
SelfTec® 16/10	10	160
SelfTec® 16/15	15	240
SelfTec® 16/20	20	320
SelfTec® 16/X	length acc. to order (up. to 72 m)	

Table I

K

Kit selection

Selection of minimum length and winding pitch of selfregulating ELEKTRA SelfTec® cable for 1 meter of a pipe in relation to pipe diameter and ambient temperature.

		Pipe diameter (inches)												
		1/2"		3/4"		1"		1 1/4"		1 1/2"		2"		
		plastic	metal	plastic	metal	plastic	metal	plastic	metal	plastic	metal	plastic	metal	
Ambient temperature (°C)	-10°C	length (m)	1	1	1	1	1	1	1	1	1	1	1	
		pitch (m)	•	•	•	•	•	•	•	•	•	•	•	
	-20°C	length (m)	1	1	1,1	1	1,3	1	1,6	1,1	1,8	1,2	2,1	1
		pitch (m)	•	•	18,5	•	12,5	•	11	29	10	23	10	17
	-30°C	length (m)	1,5	1	1,7	1,1	2	1,3	2,3	1,6	2,5	1,8	3	2,2
		pitch (m)	6	•	6	18,5	6	12,5	6,5	10,5	7	10	7	9,5

Table 2

NOTE: In case of pipes of diameters, for which no pitch is given in the table, the heating cable should be laid along.

Example

Suppose that there is a need to protect a plastic pipe of 1-1/2 in. diameter.

The lowest expected temperature in the climatic zone, where the pipe is used, is -30°C. The length of the pipe to be heated is 1.75 m. It can be read from the table I that for the diameter in question for 1 meter of the pipe minimum 2.5 m of the cable is needed. For a pipe 1.75 m long at least $1.75 \times 2.5 \text{ m} = 4.38 \text{ m}$ is needed. Select from the Table I a cable of the length closest to 4.38 m. In this case it will be the ELEKTRA SelfTec® I6/5, 5 m long.

The cable pitch is calculated from the formula:

$$p = \frac{\pi(D + d)L_R}{\sqrt{L_P^2 - L_R^2}} \quad \text{Formula I}$$

where:

D - pipe diameter (1 in. = 2,54 cm);

d - cable diameter = 0,5 cm;

L_P - cable length;

L_R - pipe length.

In our example we assume:

D – 1,5 × 2,54 cm = 3,81 cm

d – 0,5 cm

L_P – 500 cm

L_R – 175 cm

$$p = \frac{3,14(3,81 + 0,5)175}{\sqrt{500^2 - 175^2}} = \frac{2368,35}{\sqrt{219375}} = \frac{2368,35}{468,37} = 5,06 \text{ cm}$$

Installation

Installation of ELEKTRA SelfTec® system selfregulating cable is very easy and practically everyone is capable of doing it. It does not require complicated equipment or special tools. The most important part of the system is the selfregulating heating cable. Depending on the application, there are various ways of installing the selfregulating heating cable:

ON PIPES

- If it results from the Table 2 (page 6) that the cable length is the same as the pipe length, the cable is installed along the pipe. Fix the cable to the pipe by the use of tape (included in the kit) as on the drawing.
- Around the pipe: wind the heating cable around the pipe and fix it with the tape (included) every 200 mm. To make uniform winding easier, calculate the spacing between cables from the formula 1.

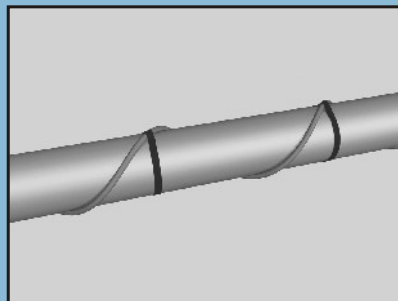
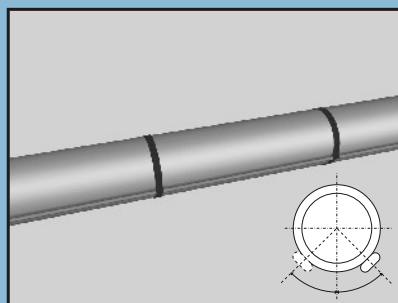

Pipes should also be insulated. The thickness of thermal insulation layer must be minimum 10 mm for pipes up to 1 in. diameter, and at least 15 mm for pipes up to 2 in. diameter.

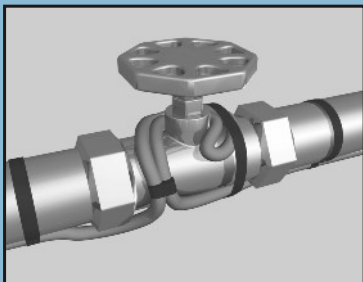

ON VALVES

Method of installation is shown on the drawing. Laying the cable is different for various valve shapes and cable lengths. Install the cable in such a manner that in case there is a need to remove the valve, the heating cable does not have to be cut. Always remember to protect the valve with thermal insulation.

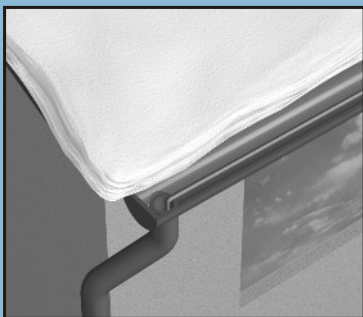

IN GUTTERS AND DOWN PIPES

Place the heating cable along the gutter.

The heating cable must always be conducted above the pipeline or gutter suspension or fixing elements. The heating cable must not be pressed to the protected element with a band or clamping.

Heating cables must not be installed on movable elements.

Avoid:

- chemically aggressive environment;
- sharp edges;
- bending and squeezing;
- stepping or driving on the cable.

Warranty Card

ELEKTRA provides a 3-year warranty (from the date of purchase) for the SelfTec[®] heating cable.

Warranty terms:

- 1) The complaint can only be recognized if:
 - a) The heating system is fitted according to this installation manual
 - b) Heating cable proof of purchase is produced

- 2) Any repairs carried out by a person other than an authorized ELEKTRA technician shall render the warranty null and void.

- 3) The warranty does not cover damage caused by:
 - a) Mechanical damage
 - b) Incorrect power supply
 - c) Lack of overload protection and residual current protection
 - d) Electrical system installed contrary to applicable regulations

- 4) Under the warranty ELEKTRA shall only cover any costs related to repairing or replacing the defective heating cable.

ATTENTION! Claims must be submitted together with the Warranty Card and proof of purchase at the point of sale where the product was purchased or at an ELEKTRA office.



SILVER ACE '93



BRONZE HELMET '97



SILVER HELMET '88



GOLD HELMET '97



GOLD MEDAL
2001



BUSINESS GAZELLES
2006



Gazela
Biznesu
BUSINESS GAZELLES
2007



Gazela
Biznesu
BUSINESS GAZELLES
2008



BUDOOWLANA
FIRMA
ROKU 2008
FIRM OF THE YEAR
2008



Version: January 2012

ul. Marynarska 14
02-674 Warszawa, Poland
tel.: (+48 22) 843 32 82
fax: (+48 22) 843 47 52
e-mail: office@elektra.eu
www.elektra.eu

